

# GENERAL SPECIFICATIONS

NO. REQ'D: (1)  
 CAPACITY: 350 GALLONS  
 TYPE: HTC, HIGHGUARD, DW TYPE I 360  
 MATERIAL: MILD CARBON STEEL  
 FLOW RATE: 35 GPM  
 GAUGE: BASED ON 60" MAX BURIAL

	INNER	OUTER
SHELL-	7 GA.	10 GA.
HEADS-	7 GA.	10 GA.

**SURFACE PREP:**  
 SSPC NO.6 BLAST ALL EXTERIOR SURFACES  
 SSPC NO.10 BLAST ALL INTERIOR SURFACES

COATING:	MATERIAL	THICKNESS
EXTERIOR-	HIGHGUARD	(75 MILS)
INTERIOR-	CHEMLINE 4200 PW	(15 MILS)

**CONSTRUCTION :**  
 LAP FIT & WELD ALL EXTERIOR SEAMS  
**OPERATING PRESSURE :** ATMOSPHERIC

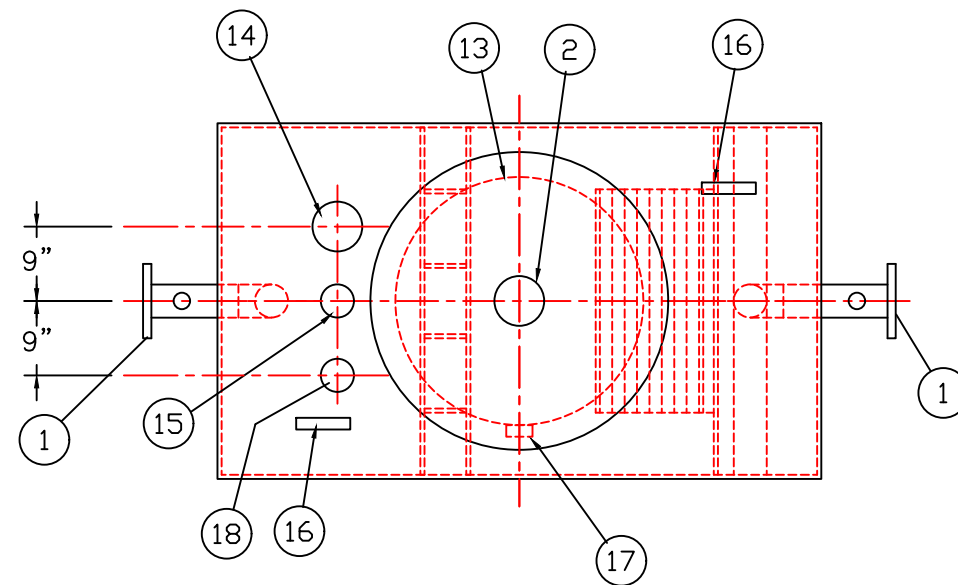

PLAN

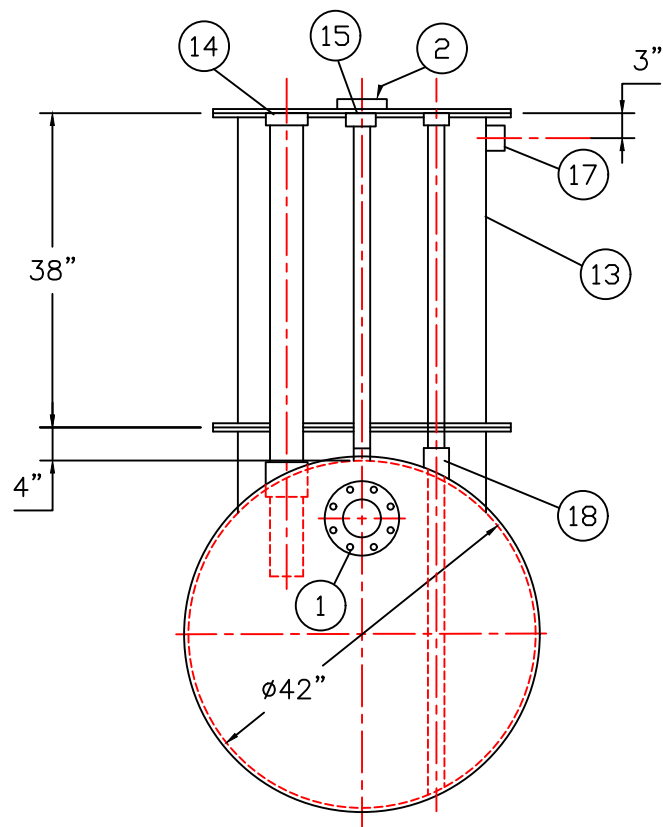

END VIEW

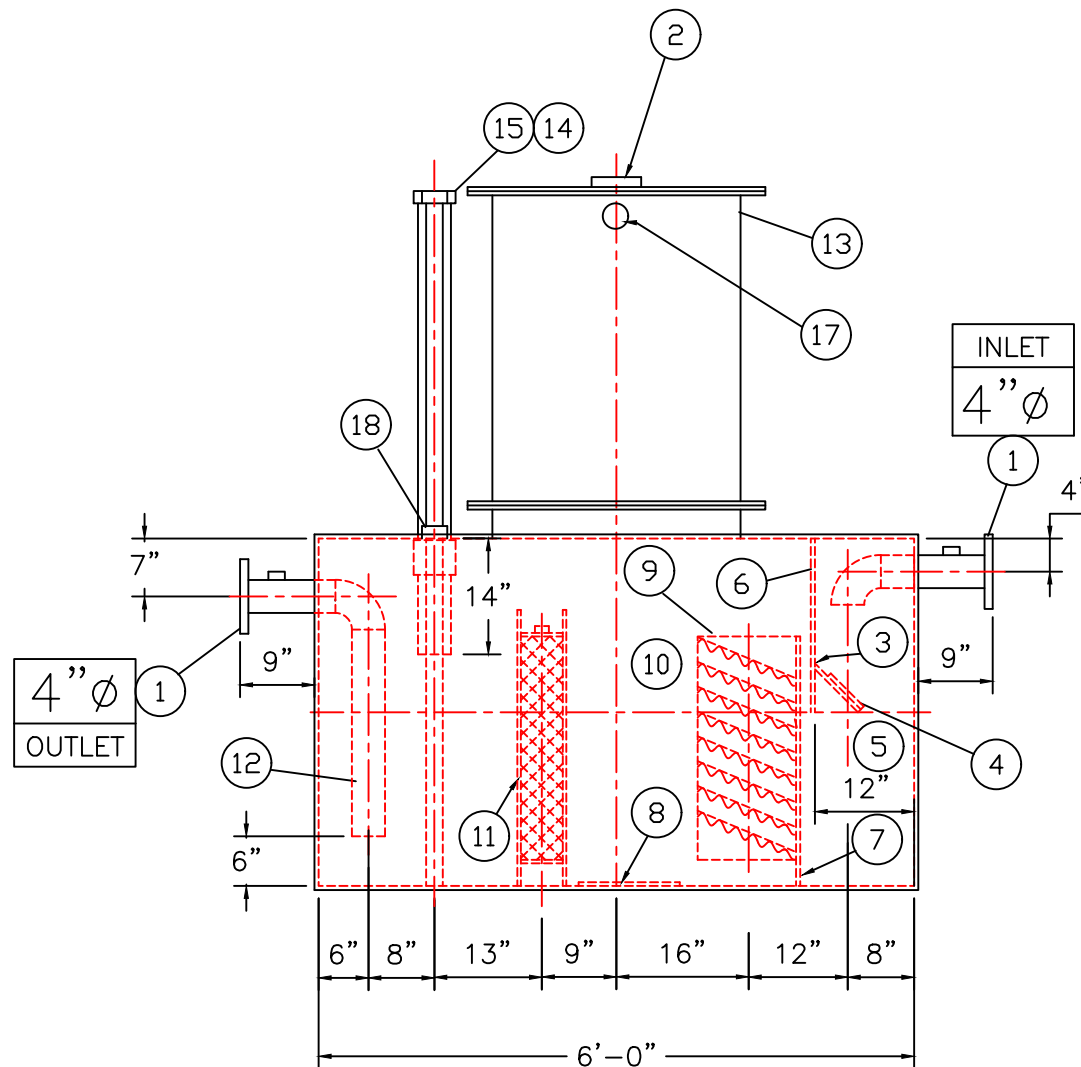

ELEVATION

# PROVIDED EQUIPMENT

- 150# R.F.S.O. FLANGE W/ 2" FNPT FOR VENT
- 4"Ø FNPT FOR GAUGE WITH PLUG
- VELOCITY HEAD DIFFUSION BAFFLE
- WEAR PLATE
- SEDIMENT CHAMBER
- UNDERFLOW BAFFLE (REMOVABLE)
- SLUDGE BAFFLE
- STRIKER PLATES
- PARALLEL CORRUGATED PLATE COALESCER. CORELLA PVC PLATES (3" PLATE SPACING)
- OIL/WATER SEPARATOR CHAMBER
- 6" THICK PETROSCREEN COALESCER MATERIAL INSTALLED W/ PULL ROD SHIPPED LOOSE
- STEEL OUTLET DOWNCOMER
- 30"Ø MANWAY WITH BOLT-ON EXTENSION SHIPPED LOOSE
- 4"Ø FNPT FOR OIL PUMP-OUT WITH INTERNAL PVC PIPE INSTALLED & RISER PIPE SHIPPED LOOSE
- 2"Ø FNPT FOR LEVEL SENSOR WITH RISER PIPE SHIPPED LOOSE
- LIFTING LUG
- 2"Ø FNPT FOR VENT
- 2"Ø FNPT FOR LEAK SENSOR WITH RISER PIPE SHIPPED LOOSE

# ANCILLARY PROVIDED EQUIPMENT

- (2) 30" FIBREFLEX MANWAY GASKETS
- (2) SETS OF NUTS/BOLTS/WASHERS FOR 30" MANWAY

# NOTES

- POLYURETHANE HIGHGUARD TANK IS NOT APPROVED FOR THE STORAGE OF HEATED PRODUCTS
- ALL VENT PIPING BY INSTALLER
- 15000 VOLT SPARK TEST PROVIDED AT FACTORY

# REVISIONS



# Highland Tank

U.S. Patent #4,722,800 Canadian Patent # 1,296,263

350 GALLON OIL WATER SEPARATOR  
 HTC, HIGHGUARD, DW TYPE I 360

CUSTOMER:

PROJECT:

QUOTE NO:

CHK'D BY:

UNLESS OTHERWISE SPECIFIED DIMENSIONS ARE IN INCHES  
 TOLERANCES ARE + OR - 1"

SCALE: 1/2"=1'-0"

DATE:

DWG. BY:

DWG. NO.:

00350HGDWHTCHDS

NOTE :  
 ALL RIGHTS RESERVED. THIS DRAWING OR ANY PART THEREOF MUST NOT BE REPRODUCED IN ANY FORM WITHOUT THE WRITTEN PERMISSION OF HIGHLAND TANK.  
 HIGHLAND TANK SHALL BE RESPONSIBLE ONLY FOR ITEMS INDICATED ON THIS FABRICATION DRAWING UNLESS OTHERWISE NOTED. CUSTOMER IS RESPONSIBLE FOR VERIFYING CORRECTNESS OF SIZE / LOCATION OF FITTINGS , ACCESSORIES & COATINGS SHOWN ON THIS DRAWING

# GENERAL SPECIFICATIONS

NO. REQ'D: (1)  
 CAPACITY: 350 GALLONS  
 TYPE: HTC, HIGHGUARD, DW TYPE I 360  
 MATERIAL: MILD CARBON STEEL  
 FLOW RATE: 35 GPM  
 GAUGE: BASED ON 60" MAX BURIAL

	INNER	OUTER
SHELL-	7 GA.	10 GA.
HEADS-	7 GA.	10 GA.

**SURFACE PREP:**  
 SSPC NO.6 BLAST ALL EXTERIOR SURFACES  
 SSPC NO.10 BLAST ALL INTERIOR SURFACES

COATING:	MATERIAL	THICKNESS
EXTERIOR-	HIGHGUARD	(75 MILS)
INTERIOR-	CHEMLINE 4200 PW	(15 MILS)

**CONSTRUCTION :**  
 LAP FIT & WELD ALL EXTERIOR SEAMS  
**OPERATING PRESSURE :** ATMOSPHERIC

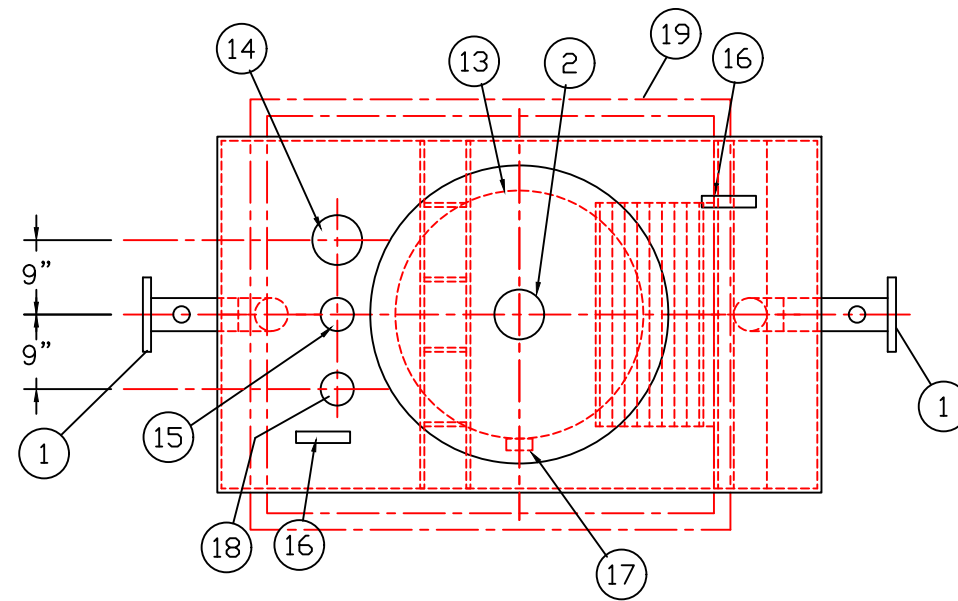

PLAN

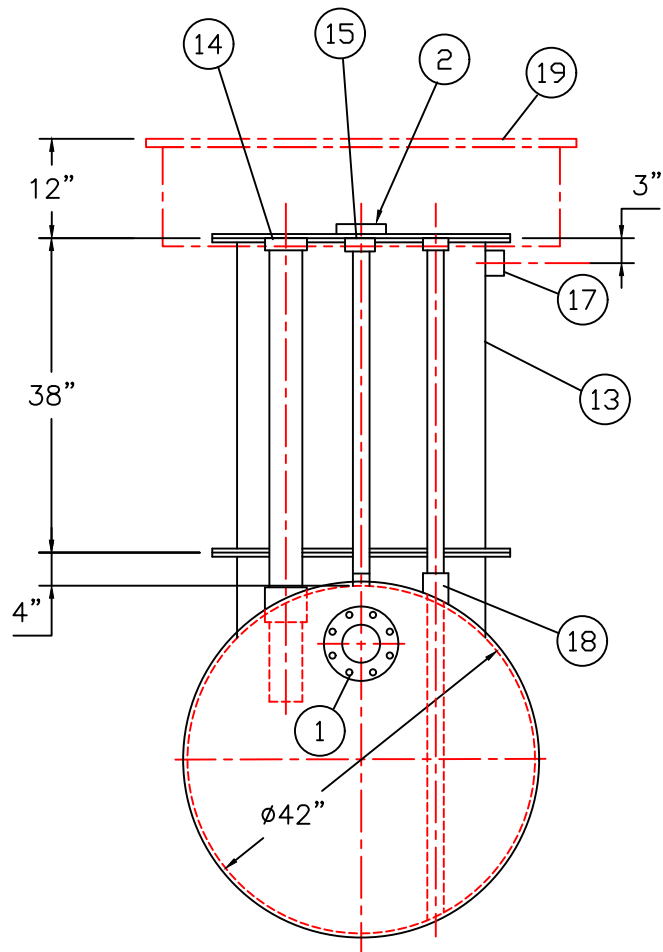

END VIEW

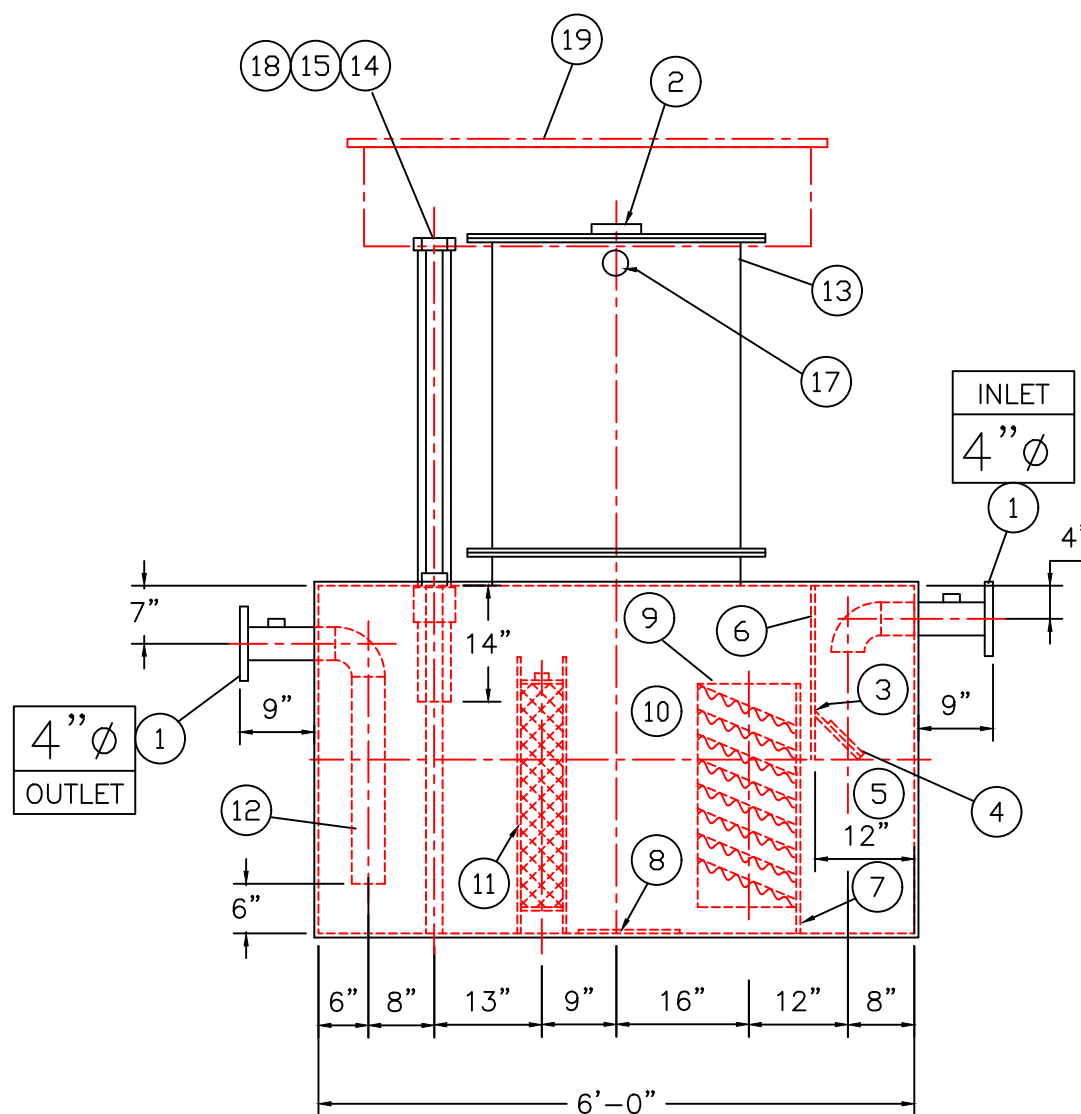

ELEVATION

# PROVIDED EQUIPMENT

- 150# R.F.S.O. FLANGE W/ 2" FNPT FOR VENT
- 4"Ø FNPT FOR GAUGE WITH PLUG
- VELOCITY HEAD DIFFUSION BAFFLE
- WEAR PLATE
- SEDIMENT CHAMBER
- UNDERFLOW BAFFLE (REMOVABLE)
- SLUDGE BAFFLE
- STRIKER PLATES
- PARALLEL CORRUGATED PLATE COALESCER. CORELLA PVC PLATES (3" PLATE SPACING)
- OIL/WATER SEPARATOR CHAMBER
- 6" THICK PETROSCREEN COALESCER MATERIAL INSTALLED W/ PULL ROD SHIPPED LOOSE
- STEEL OUTLET DOWNCOMER
- 30"Ø MANWAY WITH BOLT-ON EXTENSION SHIPPED LOOSE
- 4"Ø FNPT FOR OIL PUMP-OUT WITH INTERNAL PVC PIPE INSTALLED & RISER PIPE SHIPPED LOOSE
- 2"Ø FNPT FOR LEVEL SENSOR WITH RISER PIPE SHIPPED LOOSE
- LIFTING LUG
- 2"Ø FNPT FOR VENT
- 2"Ø FNPT FOR LEAK SENSOR WITH RISER PIPE SHIPPED LOOSE
- R-GLM-5448/2 RECTANGULAR GRADE LEVEL MANWAY

# ANCILLARY PROVIDED EQUIPMENT

- (2) 30" FIBREFLEX MANWAY GASKETS
- (2) SETS OF NUTS/BOLTS/WASHERS FOR 30" MANWAY

# NOTES

- POLYURETHANE HIGHGUARD TANK IS NOT APPROVED FOR THE STORAGE OF HEATED PRODUCTS
- ALL VENT PIPING BY INSTALLER
- 15000 VOLT SPARK TEST PROVIDED AT FACTORY

# REVISIONS



# Highland Tank

U.S. Patent #4,722,800 Canadian Patent # 1,296,263

350 GALLON OIL WATER SEPARATOR  
 HTC, HIGHGUARD, DW TYPE I 360

CUSTOMER:

PROJECT:

QUOTE NO:

CHK'D BY:

UNLESS OTHERWISE SPECIFIED DIMENSIONS ARE IN INCHES  
 TOLERANCES ARE + OR - 1"

SCALE: 1/2"=1'-0"

DATE:

DWG. BY:

DWG. NO.:

00350HGDWHTCHDS

NOTE :  
 ALL RIGHTS RESERVED. THIS DRAWING OR ANY PART THEREOF MUST NOT BE REPRODUCED IN ANY FORM WITHOUT THE WRITTEN PERMISSION OF HIGHLAND TANK.  
 HIGHLAND TANK SHALL BE RESPONSIBLE ONLY FOR ITEMS INDICATED ON THIS FABRICATION DRAWING UNLESS OTHERWISE NOTED. CUSTOMER IS RESPONSIBLE FOR VERIFYING CORRECTNESS OF SIZE / LOCATION OF FITTINGS , ACCESSORIES & COATINGS SHOWN ON THIS DRAWING